



## G.R.A.S. 46BE 1/4" CCP Free-field Standard Microphone Set

Freq range: 4 Hz to 80 kHz  
Dyn range: 35 dBA to 160 dB  
Sensitivity: 4 mV/Pa  
Use: For general acoustic diagnostics

The G.R.A.S. 46BE is a 1/4" Constant Current Power CCP free-field microphone set for measuring high sound pressure levels at high frequencies. It is terminated with a 10/32 UNC microdot female connector and is TEDS compatible. The equivalent traditional 200 V LEMO type is G.R.A.S. 46BF.

### Technology

---

#### Introduction

Through a close cooperation with our customers, we know that data-safety is highly important because the costs related to unsuited and unreliable sensors may determine whether your project turns into a success or not.

For our users, data safety translates directly into requests for easier microphone selection, simple system configuration and reduction of measurement errors.

To meet these requirements, we invented the microphone set concept. It is simple, reliable and robust and consists of a microphone cartridge and preamplifier combination, which is calibrated as one unit. This eliminates errors because there is only one sensitivity value to account for and the risk of contaminating the interface is eliminated. Combine this with our unique and proven design and you have the most reliable measurement microphone sets available in the industry today.

**G.R.A.S.**  
SOUND & VIBRATION

## Typical applications and use

The 46BE is a free-field microphone set and as such optimized for all acoustic applications, where the location of the main sound source is known and the microphone can be pointed directly at it ensuring 0° incidence. However it should be noted that the small size of the 1/4" microphone body and diaphragm also enables pressure and random-incidence (diffuse field) measurements up to 20 kHz without removing the protection grid or need for further compensation. This all-use feature is very useful if you are not able to point out the nature of your sound field.)

The high cut-off frequency makes it ideal for ultra-sonic diagnostics and impulse measurements, where minimum distortion and high resolution are obtained by the small size and fast response of the diaphragm.

Regarding temperature range, see the Specifications. Should higher temperature limits be required, we recommend considering the G.R.A.S. probe microphones where the microphone and preamplifier can be isolated from the hot source.

## Design

The G.R.A.S. 46BE is a high-performance 1/4" free-field standard microphone set for measuring high sound pressure levels at high frequencies. In our clean-room environment the set is assembled and sealed with a label. However, the microphone set can be dismounted, if you wish to use the components separately.

### Microphone

The microphone cartridge is the high-quality IEC 61094 WS3F standardized [G.R.A.S. 40BE](#) 1/4" Pre-polarized Free-Field Microphone, designed for long-term reliability in multiple environments.

The pre-polarization is obtained through an electret that is inflicted on the microphone back-plate under highly controlled conditions. The electret is then charged to match the specified microphone sensitivity.

### Preamplifier

The preamplifier is the [G.R.A.S. 26CB](#) 1/4" CCP Standard Preamplifier with Microdot connector, and based on our well-known circuit board substrates. In the industry these are famous for their low self-noise, wide frequency and excellent slew rate performance.

## Compatibility

To perform as specified the G.R.A.S. 46BE microphone set requires a constant current input module that can deliver 4 mA and 24 V unloaded CCP voltage supply. If the constant current supply is lower, the capability of driving long cables is reduced and consequently the upper frequency is reduced. If the voltage supply is lower it will influence the upper dynamic range.

The microphone set is terminated with a 10/32 UNC Microdot female connector. Ready to use coax cable assemblies of various types and lengths are available in standard as well as customized lengths.

The 46BE is IEEE 1451.4 TEDS v. 1.0 compliant. If your measurement platform supports Transducer Electronic Data Sheets you will be able to read and write data like properties and calibration data.

## System verification

The functionality of TEDS is very useful to determine which microphone is connected to which input channel. However, it is not a check of whether the microphone is within specifications or not. For daily verification and check of your measurement setup, we therefore recommend using a sound source like the [G.R.A.S. 42AB](#) Sound Calibrator.

For proper sensitivity calibration we recommend using a reference sound source like the [G.R.A.S. 42AP](#) Intelligent Pistonphone.

## Service

Should you by mistake damage the diaphragm on a G.R.A.S. microphone we will in most cases be able to exchange it at a very reasonable cost and short turn-around time. This not only protects your investment but also meets your quality assurance department since you do not have to worry about new serial numbers etc.

## Calibration

When leaving the factory, all G.R.A.S. microphones have been calibrated in a controlled laboratory environment using traceable calibration equipment. Depending on the use, measurement environment and internal quality control programs we recommend that the microphone is recalibrated at least once a year.

## Quality and warranty

G.R.A.S. microphone sets are made of components from our proven standard portfolio and are all manufactured of high-quality material and branded parts that were chosen and processed to ensure life-long stability and robustness.

All parts are manufactured and assembled at the factory in Denmark by skilled and dedicated operators in a verified clean-room environment. The microphone diaphragm, body and unique protection grid are made of high-grade stainless steel and make the microphone set resistant to physical damage as well as corrosion caused by aggressive air or gasses.

This, together with the enforced gold-plated microphone terminal guarantees a highly reliable connection. Thanks to the high quality, our warranty against defective materials and workmanship is 5 years.

## Specifications

Frequency range ( $\pm 1$ dB)	Hz	10 to 40 k
Frequency range ( $\pm 2$ dB)	Hz	4 to 80 k
Frequency range ( $\pm 3$ dB)	Hz	4 to 100 k
Dynamic range lower limit with G.R.A.S. preamplifier	dB(A)	35
Dynamic range upper limit with G.R.A.S. CCP preamplifier	dB	160

Set sensitivity @ 250 Hz ( $\pm 2$ dB)	mV/Pa	4
Set sensitivity @ 250 Hz ( $\pm 2$ dB)	dB re 1V/Pa	-48
Output impedance	$\Omega$	< 50
Output Voltage Swing, min. @ 24-28 V CCP voltage supply	Vp	8
Power supply min. to max.	mA	2 to 20
DC bias voltage, typ.	V	12
Microphone venting		Rear
IEC 61094-4 Compliance		WS3F
Temperature range, operation	$^{\circ}\text{C} / ^{\circ}\text{F}$	-30 to 70 / -22 to 158
Temperature range, storage	$^{\circ}\text{C} / ^{\circ}\text{F}$	-40 to 85 / -40 to 185
Temperature coefficient @250 Hz	dB/ $^{\circ}\text{C}$ / dB/ $^{\circ}\text{F}$	-0.01 / -0.006
Static pressure coefficient @250 Hz	dB/kPa	-0.013
Humidity range non condensing	% RH	0 to 100
Humidity coefficient @250 Hz	dB/% RH	-0.001
Influence of axial vibration @1 m/s <sup>2</sup>	dB re 20 $\mu\text{Pa}$	60
TEDS UTID (IEEE 1451.4)		27 v. 1.0
Connector type		Microdot 10/32
CE/RoHS compliant/WEEE registered		Yes/Yes/Yes
Weight	g / oz	8 / 0.282

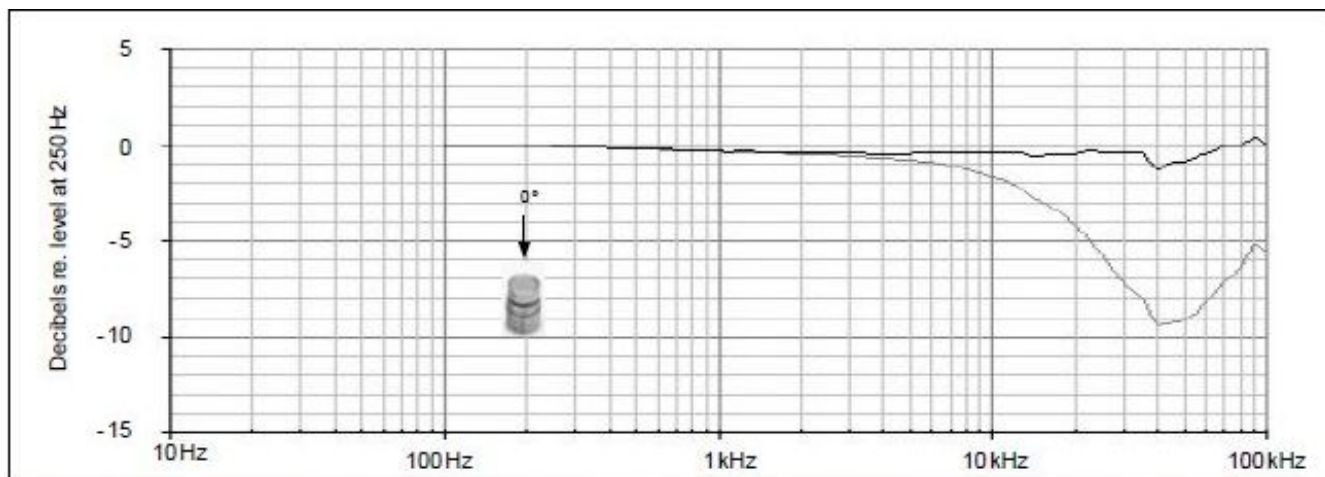

Typical frequency response (without protection grid). Upper curve shows free-field response for 0°, lower curve shows pressure response.

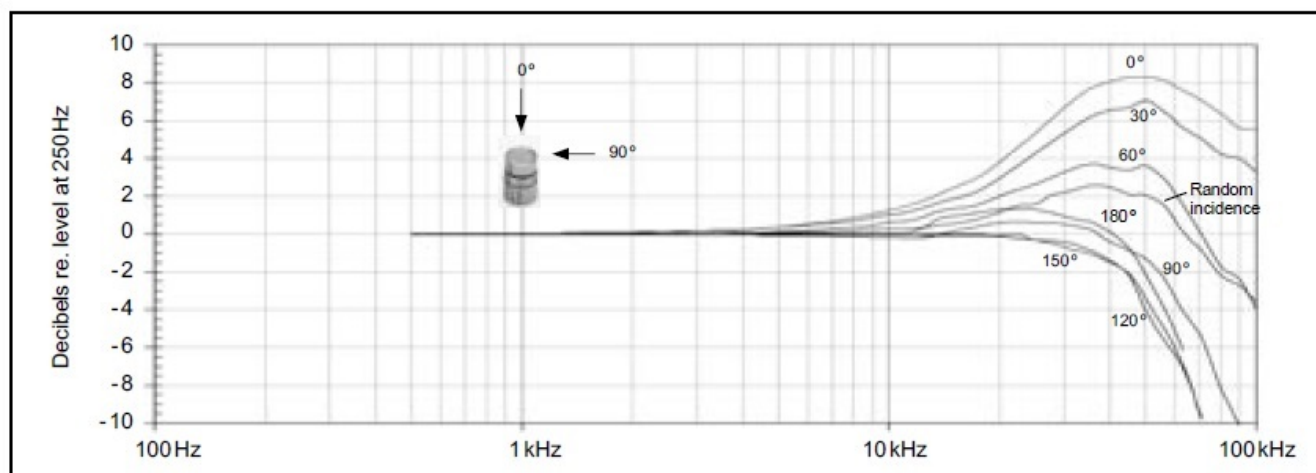

Free-field corrections for different angles of incidence

## Dimensions



Dimensions in mm

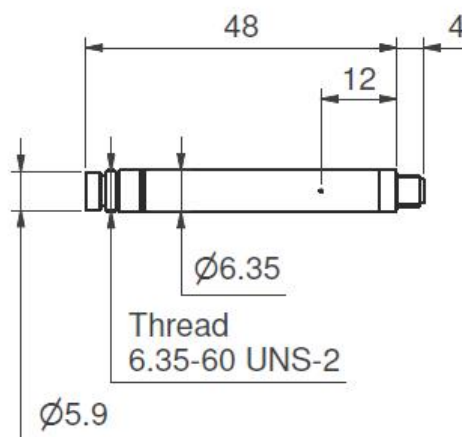
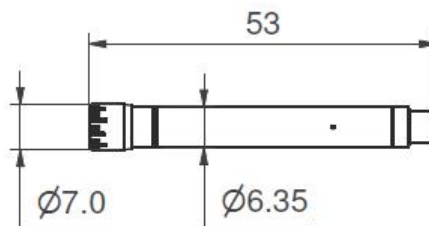

## Ordering info

**G.R.A.S.**  
SOUND & VIBRATION

## Optional items

<a href="#">G.R.A.S. AA0070</a>	3 m Microdot - BNC Cable
<a href="#">G.R.A.S. AA0073-CL</a>	Customized Length Microdot - BNC Cable
<a href="#">G.R.A.S. AA0087-CL</a>	Customized Length Microdot - Microdot Cable
<a href="#">G.R.A.S. AL0029</a>	1/4" Microphone Holder, POM
<a href="#">G.R.A.S. AL0013</a>	1/4" Microphone Holder, Stainless Steel
<a href="#">G.R.A.S. AL0005</a>	Swivel head
<a href="#">G.R.A.S. AL0006</a>	Tripod
<a href="#">G.R.A.S. RA0022</a>	1/4" Nosecone
<a href="#">G.R.A.S. AM0071</a>	Windscreen for 1/4" Microphones
<a href="#">G.R.A.S. RA0127</a>	Rain-protection cap for 1/4" microphones
<a href="#">G.R.A.S. 12AL</a>	1-Channel CCP Power Module with A-weighting filter
<a href="#">G.R.A.S. 12AQ</a>	2-Channel Universal Power Module with signal conditioning and PC interface
<a href="#">G.R.A.S. 42AB</a>	Sound Calibrator, Class 1
<a href="#">G.R.A.S. 42AP</a>	Intelligent Pistonphone, Class 0



## **We make Microphones**

---

### **Tradition**

Since the establishment in 1994, G.R.A.S. have been 100% dedicated to developing and manufacturing high-quality measurement microphones and related acoustic equipment. Founded by the Danish acoustics pioneer Gunnar Rasmussen who for more than 60 years has contributed to the world of sound and vibration with his unique ideas and designs. From the first reproducible 1" condenser measurement microphone that enabled quality measurements and instrumentation for acoustic calibration, Mr. Rasmussen's ingenuity and foresight led to the world's most popular acoustic sensor: The 1/2" measurement microphone. Then the 1/4" and 1/8" microphones followed with outstanding dynamic and high-frequency capability that brought higher definition and transparency into impulse noise diagnostics. Many variants have been made available over the years; all based on Gunnar Rasmussen's original 1" pressure microphone design.

### **Innovation**

At G.R.A.S., we and our customers benefit daily from Mr. Rasmussen's exceptional understanding of acoustics, physics, electronics and measurement needs. Not only in R&D but throughout the organisation, we are proud to develop, produce and offer the broadest range of high-quality measurement microphones and accessories in the industry. And as a family company, now owned and managed by the two sons, Per Rasmussen and Peter Wulf-Andersen, we safeguard our heritage and knowledge to help create new opportunities with our customers. We work with everybody with an interest in sound or noise within the fields of aerospace, automotive, audiology, consumer electronics, noise monitoring, building acoustics and telecommunications, metrology, education, consultancy, legislation and system integration.

### **Quality**

All our microphones are solely produced in stainless steel and in a quality that allows for a 5 year warranty. Should you by mistake damage the diaphragm on a G.R.A.S. microphone, our special technique enables repair at very reasonable price.

### **Partners**

G.R.A.S. is represented worldwide in more than 40 countries by subsidiaries and distributors. Whether you are searching for a multi-channel solution or just a replacement microphone for your sound level meter G.R.A.S. will help solve your needs. Visit [gras.dk](http://gras.dk) for your local G.R.A.S. partner.