

A Web based Instrumentation Platform for Use in Distance Learning

Jay R. Porter and Joseph A. Morgan

**Electronics Engineering Technology Program
Texas A&M University, College Station, TX 77843-3367**

Introduction

Enabling distance learning is becoming increasingly important to the mission of today's institutions of higher education. Much work is being performed to offer online courses that make education accessible to those who do not fit the model of the traditional full-time student.^{1,2} Tools such as WebCT™ make the task of offering a typical lecture course via the Internet straightforward.³ Unfortunately, while this works well for lecture courses, educational programs that rely on a hands-on learning approach must develop meaningful laboratory experiences that can be delivered via the World Wide Web. Many universities have ongoing efforts in this area.^{4,5}

The Electronics and Telecommunication Engineering Technology (EET/TET) programs at Texas A&M University are currently evaluating methods for offering distance education laboratories. To accomplish this, a subset of the programs' laboratory-intensive courses is currently being evaluated and tested by the current student body. One course in particular, Computer-based Instrumentation and Control, has offered unique challenges requiring innovative solutions. In this course, students learn the basics of computer-based instrumentation including analog and digital data acquisition, software-based signal conditioning, and industry standard instrumentation platforms. The first five weeks of the semester are devoted to individual labs that teach analog-to-digital conversion, digit-to-analog conversion, digital input/output, and transducer interface. The lab then culminates in a ten-week project where students interface to motors, transducers, and sensors and create an operational mobile platform that can be remotely monitored and controlled.

To solve the challenge of making an instrumentation platform that is accessible from the web, the authors have chosen to use National Instruments' Fieldpoint™ data acquisition system and LabVIEW™ RealTime software development environment.⁶ The use of Fieldpoint in the lab allows students to create LabVIEW code on any PC-based platform. They can then download their code to the Fieldpoint target hardware and test it over the Internet. In this manner, they can perform data acquisition and signal-conditioning experiments remotely. Because the platform also has to be mobile for the second part of

the course, an 802.11b wireless network has been installed in the building. The students can download their code and test drive the platform, untethered by wires. LabVIEW RT allows the platform to run controller software independent of a personal computer. The platform is controlled through the use of a Datasocket™ data server that is also Internet based. Web cameras allow the students to view the platform while remotely executing their software.

Course Structure

The Computer-based Instrumentation and Control course is divided into three major sections. The first section provides students with a refresher for the LabVIEW graphical programming environment and focuses their work on using data acquisition (DAQ) cards installed in personal computers to perform various control and interfacing laboratory assignments. At the end of this section, the students are introduced to the Field Point hardware and LabVIEW RT software. This material is generally completed during the first five to six weeks of the semester. During this block, classroom activities lead the actual laboratory work. In class, the students study data acquisition/control technology, understand how the technology is implemented in a particular device, and then see how National Instruments utilizes the device and associated circuitry on its DAQ cards. Laboratory assignments normally include digital I/O, digital-to-analog conversion, analog-to-digital conversion, and time/frequency measurements. In addition, the students complete a laboratory assignment using network socket programming available in the LabVIEW development environment. The DAQ card currently used in this course is the PCI 6024 General Purpose Data Acquisition Card.

The other two major sections share the second two-thirds of the semester. In class, the students learn about signal conditioning – designing and implementing circuits that begin with a wide range of sensors and include typical conversion, instrumentation amplifiers, offset amplifiers, and filter circuits. Combined with this educational material is the course project.

At the end of week five, the students form four-person teams to satisfy the requirements contained in the course project's Scope of Work. Working in both a cooperative as well as competitive mode, the groups must share the “platform” that is the focus for the course project. In the past, the platform has been a titration and measurement station used by the Texas A&M College of Medicine to support research activities, a rotating machine simulator used as an exhibit demonstration station by private industry, and a performance monitoring system for a Formula SAE race car being design and built for national competition by the Mechanical Engineering Department. Most recently, a self-powered, mobile platform that is monitored and controlled via a wireless network infrastructure has been the platform of choice. The student teams must cooperate to schedule and gain access to the platform to test their design and development efforts as well as identify and solve common problems. The teams must also share technical documentation and information gained through direct contact with the project sponsor or engineering staff for various components installed on the platform.

The student teams must also compete with all other teams to develop the best control and monitoring system for the platform. The students are required to meet all of the basic requirements for the project before the team is able to move on to more advanced requirements. Once the advanced requirements are satisfied, the team can then suggest and deliver additional features for which they can receive a higher project grade. In concert with the technical aspects of the project, the teams also compete in producing high-quality, esthetically pleasing technical documentation that now includes a web presence. The project concludes with a formal final report that the team submits following its successful demonstration of a working project. Feedback from students indicate that the format of the course is suitable for such a project and the teams are able to integrate all facets of their education including analog and digital electronics, system-level design, data communications, testing, and technical documentation. The winning teams over the past semesters have had an opportunity to present their work at industry locations and at conference exhibits.

Members of the EET/TET faculty have decided to use this course to better evaluate the potential to deliver distance learning coursework that includes an integrated laboratory experience that can be accomplished through remote access to resources located at Texas A&M University. Several factors have recently enhanced the programs' remote access capability and the ability to deliver a more meaningful and relevant laboratory experience via a distance learning environment. Among these factors are a new IEEE 802.11b wireless local area network infrastructure that spans Fermier and Thompson Halls, the two buildings that house the EET and TET Programs and laboratories. This network allows full roaming in and around both buildings and because it is integrated into the campus network, access to the Internet is possible anywhere within the wireless coverage. The wireless network equipment was donated to the programs to support educational-based research and development activities by Cisco Systems, Inc. and was installed by students of the EET/TET Programs during the summer semester 2001.⁷ In addition to this resource, National Instruments has provided its Field Point technology for use in the course. The Field Point technology is capable of being interfaced to any Ethernet network for program download and remote control. Using the Real-Time Module for LabVIEW, it is possible to download software that was developed in the LabVIEW graphical development environment and run the resulting code on an embedded processor using a real-time operating system. Figure 1 depicts the network-based architecture that is being used to provide remote access and control of the mobile platform from a base station.

The wireless networking capability together with the real-time, network-based data acquisition and control hardware and software now make it possible to offer a series of laboratory assignments that can be performed at the student's location, then uploaded to a platform located at Texas A&M University. Using web-based camera technology, the student and instructor can simultaneously monitor the execution of the laboratory. With these resources in place, the faculty has developed a three-semester plan to implement a distance learning laboratory for this course. Currently, the development effort has just entered its second semester.

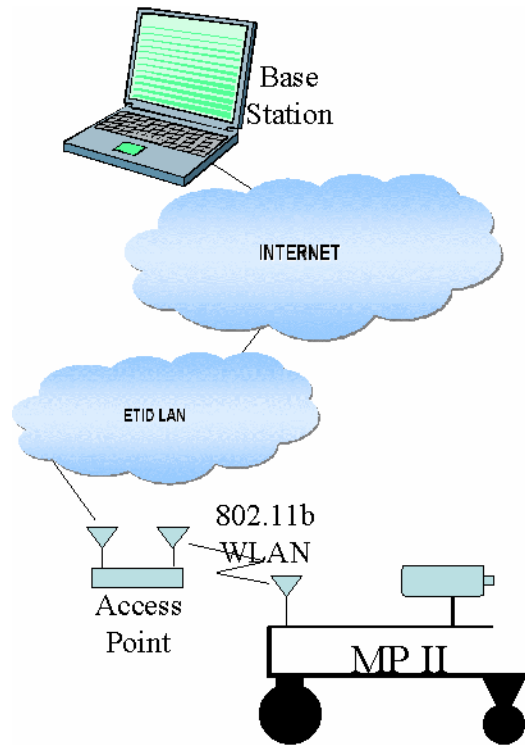

Figure 1. Network-based Architecture for Mobile Platform.

Phase I – Platform And Monitoring/Control Methodology Development

The distance learning laboratory development project began during the Fall 2001 semester. The overall goal of the first phase was to assess the learning motivation that resulted from a comprehensive set of laboratory assignments and a team project that could be successfully performed and demonstrated over the Internet. The use of WebCT has grown sufficiently at Texas A&M University that delivering the classroom lecture portion of a course via the Internet is a reasonably straightforward effort, and there are adequate support resources to assist in the production of these materials. If an integrated laboratory could be delivered that would maintain or improve the learning motivation of the students, then the EET/TET Programs could seriously consider offering coursework and professional development activities via distance learning.

In addition to this major goal, Phase I also had several other objectives. These included the overall design of a mobile platform that is easily reproducible and highly maintainable. While the platform does not have to be mobile, adding the feature of mobility stimulates the learning process and increases student interest, excitement and involvement. Control of the platform's motion also adds to the course rigor and encourages a higher level of understanding.

The Phase I objectives sought to design a power subsystem and distribution capability as well as a motor control subsystem. If the mobile platform is to be the focal point for all the laboratory assignments and the course project, the faculty believes that the platform would need to operate from a single 12V battery and be capable of continuous operation

for at least three hours. Phase I also allowed the faculty and students to implement and evaluate a wide range of Field Point hardware and utilize the LabVIEW Real-Time software in a “command” and “transparent” mode of operation between the base station and mobile platform. Finally, Phase I provided empirical data on the ability of the wireless 802.11b infrastructure to support real-time control and full-motion video while the platform roamed from access point to access point. Figure 2 contains dimensional information and Figure 3 provides a detailed view of the MP I unit. Figure 4 contains a picture of one of the student design teams testing their implementation of the LabVIEW Real-Time software that has been downloaded to the on-board Field Point processor module via a WLAN.

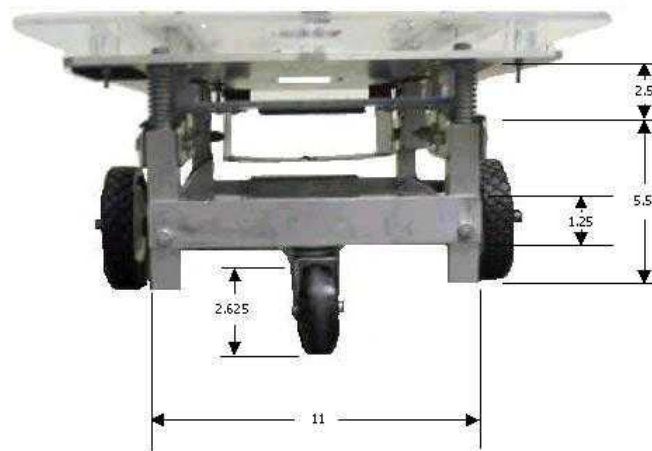

Figure 2. MP I Unit Dimensions.

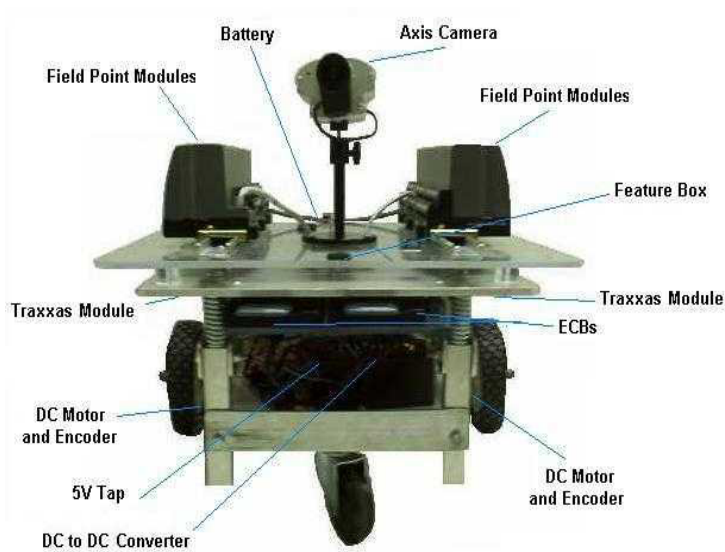

Figure 3. MP I Detailed View.



Figure 4. Student Project Team Testing the MP I System.

Phase I of the project proved very successful in increasing student learning and motivation through the design, implementation, testing and documentation processes that make up the course project. Students were able to acquire the skills necessary to develop and download code to the Field Point modules and operate the mobile platform within Thompson Hall. The feedback from all teams was extremely positive concerning the new labs and course project with the major negative being the lack of access to the common platform. This issue will be resolved in the future with multiple platforms. Over the Fall 01/Spring 02 semester break, students that had worked on the MP I units volunteered to redesign the system to improve its overall performance by implementing many of their recommendations.

Phase II – Common Platform

The success of Phase I led to a request for funding to redesign and construct two new chassis (MP II) and to equip these platforms with a common suite of hardware. During the beginning of the Spring 02 semester, students enrolled in the course volunteered to construct the two new MP II units consistent with the previous semester students' redesign. The MP II units will exhibit common power distribution and motor control subsystems, a web-based camera, Field Point modules and a new wireless capability that will support up to four static IP addresses yet require less power than the MP I wireless implementation used. The redesigned chassis weighs less and many of the mechanical difficulties of the MP I units were eliminated. Figure 5 depicts the redesigned MP II units that the Spring 02 students will use for their project. These redesigned units have more space to add additional features and capabilities.



Figure 5. MP II Units.

With a common platform now in place, more emphasis will be placed on the instrumentation and competitive aspects of the project. Such factors as sensor and actuator integration will allow the MP II units to operate in darkened environments, move autonomously in certain pre-described areas and to seek and destroy the other platform. In developing the scope of work for the Fall 02 semester, students strongly urged the faculty to include a requirement that mandated more than just a demonstration of remote control. Three design teams will be assigned to each MP II and they will compete on the basic and advanced requirements as well as the quality of their technical documentation. Once a winner from each group of three teams is decided, those two teams will lead the efforts that culminate in a “battle to the finish”. Equipped with a laser weapon (adapted from a laser tag gaming system) that can be fired a maximum of ten times, each platform will roam throughout the darkened hallways of Thompson Hall searching for the other platform. The team that scores the most “hits” on the other platform’s laser will be declared the victor. Although each platform can turn on its own running lights to locate the other mobile unit, it is expected that more creative sensor technology will be brought to bear.

Phase III Plans

Using the performance data and information that will be collected from Phase II, the EET/TET faculty will move forward on Phase III of the initiative that will create a complete laboratory experience that can be performed via remote access over the Internet. Final MP III system designs will be produced and as many as ten new units will be constructed over the summer semester with the intent to use these in a distance learning environment during the Fall 2002 semester. The complete system block diagram for the MP III units is shown in Figure 6. The MP III units will be able to host all of the introductory laboratory assignments so that the students gain experience with basic computer based instrumentation concepts and the platform’s major subsystems. During the first part of the course the platform will not be mobile. Once the student teams have demonstrated the ability to develop software, upload the code to the target system, and

operate the subsystems remotely, the team will be authorized to take control of the platform and control its movement in a pre-defined area. Working in teams where members may be geographically dispersed, students will complete the laboratory experience by implementing the requirements of the course project. Although it is expected that onsite manual intervention will be needed from time to time, these system resets, etc. should be minimal.

Conclusions

The EET/TET Programs at Texas A&M University believe that being responsive to the increasing demands for distance learning is one of their highest priorities. However, the faculty is committed to maintaining and enhancing the quality of its curricula. To meet these somewhat diametrically opposed objectives, the EET/TET Programs are working diligently to develop meaningful laboratory assignments and projects that can be successful completed and demonstrated via the Internet and World Wide Web. The Mobile Platform approach appears to be one way to increase the students learning motivation while providing a comprehensive, project-oriented laboratory experience that can be directly linked to a course such as Computer-based Instrumentation and Control.

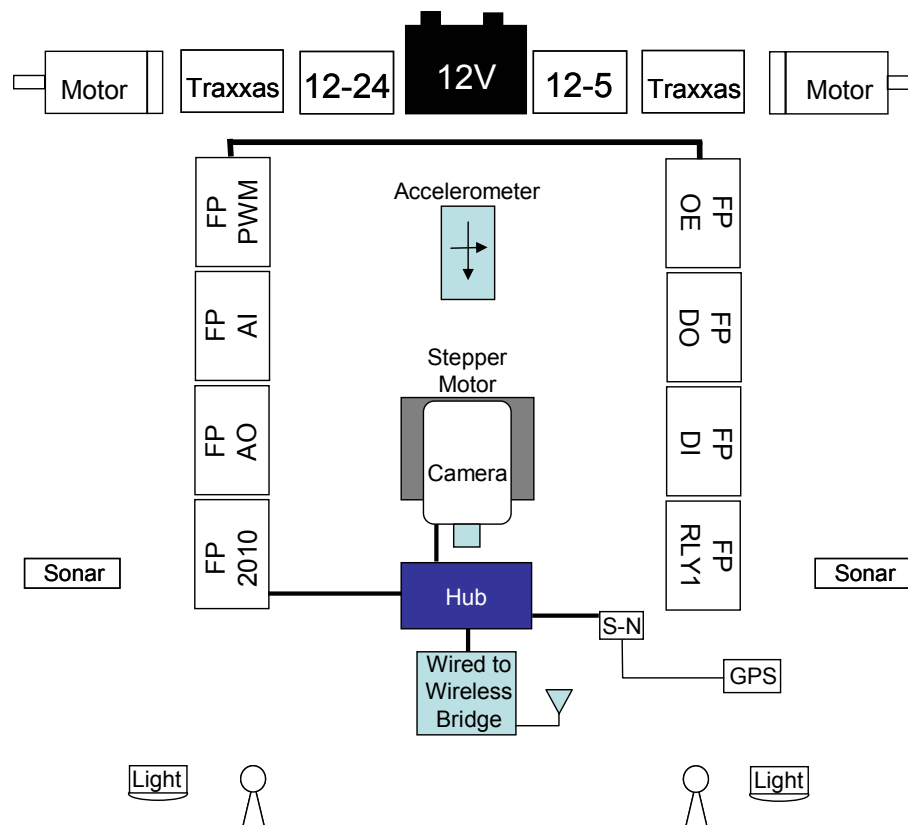

Figure 6. MP III Block Diagram.

As the project begins to unfold in the Spring 2002 semester, new laboratory assignments will be created that allow the students to understand the fundamentals of data acquisition while building a knowledge base of the various subsystems onboard the platform. The new laboratory assignments will provide students with multiple experiences in developing software in the LabVIEW environment and running the software on a remote, real-time host such as the Field Point processor. With this experience, students taking the course via distance learning could work in teams to successfully complete a course project that includes the remote monitoring and control of a mobile platform. This type of “action” appears to be very motivational for the students who bring much to the project in the way of research and add significantly to the overall capabilities. Having the real-time, full-motion video that can be shared among team members as well as the instructor also satisfies the need to demonstrate successful completion of lab assignments and the course project requirements.

As the EET/TET Programs move forward, Phase III will be used to test the new laboratory environment using students at Texas A&M as volunteers to complete all the lab assignments and project in a distance learning environment. Feedback from the Phase III experience will be integrated into the course and used to transform the laboratory-oriented courses to this new learning environment. An issue that has not been addressed at the present is the faculty time required to administer a web-based laboratory. It is expected that the time teaching assistants currently spend in the lab will be leveraged into maintaining the distance learning laboratory and communicating with students about projects. It is also anticipated that faculty time that is now lumped into lecture time and office hours will become more distributed in one-on-one interactions with the student. It is expected that this will become a faculty loading problem that will need to be solved eventually.

In addition, the Internet accessible mobile platform is being evaluated by other faculty to host remote laboratory assignments in courses such as advanced digital logic, microprocessors, and senior design. Having a common system that is used in multiple courses would better facilitate the remote laboratory process. Once students learn how to interface to the remote platform to program and execute onboard experiments, this experience can be leveraged in subsequent courses that can build on the capabilities developed in lower-level courses. Although considerable work is still left to do, the EET/TET faculty is optimistic about using the Mobile Platform as a basis for Internet-based laboratories that meet the educational objectives of maintaining the hand-on approach to learning while motivating the student to go beyond the minimum requirements.

More information on the computer-based instrumentation and control course and the MP I project results can be found on the EET/TET website.⁸ Web-based documentation has become an integral part of the students’ requirements to effectively communicate the technical aspects of their work in a manner that is designed to intrigue and engage the audience. In addition, many industry representatives have been more responsive in their support of the course projects based on the recognition they receive on these web pages.

The web page approach to documentation and information dissemination also lends itself to distance learning.

References

1. Latchman, H.A., Latchman, S.M., "Bringing the Classroom to Students Everywhere," *Journal of Engineering Education*, October 2000, pp. 429-433.
2. Penfield, P., Larson, R., "Education Via Advanced Technologies," *IEEE Transactions on Education*, Vol. 39, No. 3, pp. 436-443.
3. URL: <http://www.webct.com>.
4. Chetty, M. and Dabke, K., "Towards a Web-based control engineering laboratory," *International Journal of Electrical Engineering Education*, Vol. 37, No. 1, pp. 38-47.
5. Miele, D., Potsaid, B., Wen, J., "An Internet-based Remote Laboratory for Control Education," *Proceedings of the American Control Conference*, Arlington, VA, June 25-27, 2001, pp. 1151-1152.
6. URL: <http://www.ni.com>.
7. URL: <http://wip.tamu.edu>.
8. URL: <http://entc359.tamu.edu>.

JAY PORTER

Jay R. Porter joined the Department of Engineering Technology and Industrial Distribution at Texas A&M University in 1998 as an Assistant Professor and currently works in the areas of mixed-signal circuit testing and virtual instrumentation development. He received the BS degree in electrical engineering (1987), the MS degree in physics (1989), and the Ph.D. in electrical engineering (1993) from Texas A&M University.

JOSEPH MORGAN

Joseph A. Morgan joined the Engineering Technology program at Texas A&M University in 1989 as the Program Coordinator for Electronics and Telecommunications Engineering Technology. His current areas of interest included radar systems, data acquisition, and control systems. He received the MS degree in industrial engineering, and the D.E. in industrial engineering from Texas A&M University.